

SIEMENS

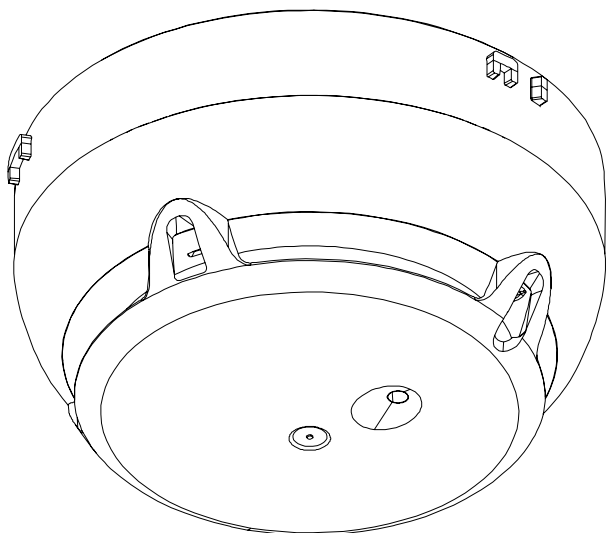

FDOOT271-O

Radio fire detector

Technical Manual

Legal notice

Technical specifications and availability subject to change without notice.

Transmittal, reproduction, dissemination and/or editing of this document as well as utilization of its contents and communication thereof to others without express authorization are prohibited. Offenders will be held liable for payment of damages. All rights created by patent grant or registration of a utility model or design patent are reserved.

Issued by:
Siemens Switzerland Ltd.
Building Technologies Division
International Headquarters
Gubelstrasse 22
CH-6301 Zug
Tel. +41 41 724-2424
www.siemens.com/buildingtechnologies

Edition: 2017-01-24
Document ID: A6V10425624_en--_e

© Siemens Switzerland Ltd, 2014

Table of contents

1	About this document	5
1.1	Applicable documents	7
1.2	Download center	8
1.3	Technical terms and abbreviations	8
1.4	History of changes	9
2	Safety	10
2.1	Safety instructions	10
2.2	Safety regulations for the method of operation	12
2.3	Standards and directives complied with	14
2.4	Release Notes	14
3	Structure and function	15
3.1	Overview	15
3.1.1	Details for ordering	15
3.1.2	Product version ES	16
3.1.3	Sensory	17
3.2	Power supply	18
3.3	Function	19
3.3.1	Parameter sets	19
3.3.2	Danger levels	19
3.3.3	Diagnosis levels	19
3.3.4	Internal alarm indicator	20
3.3.5	Renovation mode	22
3.3.6	Test mode	22
3.3.7	Interface to service devices	22
3.4	Mechanical setup	23
3.5	Accessories	23
3.5.1	Battery pack BAT3.6-10	23
3.5.2	Detector base FDB271	24
3.5.3	Detector locking device FDBZ293	24
3.5.4	Designation plate FDBZ291	24
3.5.5	Detector dust cap FDZ291	24

4	Planning	25
4.1	Ambient features	25
4.2	Parameter sets for FDOOT271-O	26
4.2.1	Sensor mode 0 'Neural fire detector'	26
4.2.1.1	Description	26
4.2.1.2	Use	26
4.2.1.3	Specification	27
4.2.2	Sensor mode 1 'Heat detector'	27
4.2.2.1	Description	27
4.2.2.2	Specification	28
4.2.3	Sensor mode 2 'Smoke detector'	28
4.2.3.1	Description	28
4.2.3.2	Use	29
4.2.3.3	Specification	29
4.3	Application examples	29
5	Mounting / Installation	30
5.1	Required space	30
5.2	Detector base FDB271	30
5.3	Mounting radio fire detector FDOOT271-O	31
5.4	Detector locking device FDBZ293	33
5.5	Designation plate FDBZ291	34
6	Commissioning	35
7	Maintenance / Repair	36
7.1	Status query	36
7.2	Performance check	36
7.3	Testing detectors	37
7.4	Confirming the detector position	37
7.5	Establishing factory settings	38
7.6	Basic principles for replacing the battery pack	39
7.7	Replacing the battery pack	40
8	Specifications	42
8.1	Technical data	42
8.2	Dimensions	44
8.3	Environmental compatibility and disposal	45
	Glossary	46
	Index	47

1 About this document

Goal and purpose

This document contains information on the radio fire detector FDOOT271-O. Following the instructions consistently will ensure that the product can be used safely and without any problems.

Intended use

The radio fire detector FDOOT271-O may only be used in a fire detection system in a detector base FDB271 together with a radio gateway approved by the manufacturer.

The radio fire detector FDOOT271-O is compatible with the radio module FDRF272-O.

Target groups

The information in this document is intended for the following target groups:

Target group	Activity	Qualification
Product Manager	<ul style="list-style-type: none"> Is responsible for information passing between the manufacturer and regional company. Coordinates the flow of information between the individual groups of people involved in a project. 	<ul style="list-style-type: none"> Has obtained suitable specialist training for the function and for the products. Has attended the training courses for Product Managers.
Project Manager	<ul style="list-style-type: none"> Coordinates the deployment of all persons and resources involved in the project according to schedule. Provides the information required to run the project. 	<ul style="list-style-type: none"> Has obtained suitable specialist training for the function and for the products. Has attended the training courses for Project Managers.
Project engineer	<ul style="list-style-type: none"> Sets parameters for product depending on specific national and/or customer requirements. Checks operability and approves the product for commissioning at the place of installation. Is responsible for troubleshooting. 	<ul style="list-style-type: none"> Has obtained suitable specialist training for the function and for the products. Has attended the training courses for Product Engineer.
Installation personnel	<ul style="list-style-type: none"> Assembles and installs the product components at the place of installation. Carries out a performance check following installation. 	<ul style="list-style-type: none"> Has received specialist training in the area of building installation technology or electrical installations.
Maintenance personnel	<ul style="list-style-type: none"> Carries out all maintenance work. Checks that the products are in perfect working order. Searches for and corrects malfunctions. 	<ul style="list-style-type: none"> Has obtained suitable specialist training for the function and for the products.

Source language and reference document

- The source/original language of this document is German (de).
- The reference version of this document is the international version in English. The international version is not localized.

Document identification

The document ID is structured as follows:

A6Vxxxxxxxx_aaAA_vv

A6Vxxxxxxxx_--AA_vv

A6Vxxxxxxxx_aa--_vv

A6Vxxxxxxxx_----_vv

ID code ¹	Description
A6Vxxxxxxxx	STEP-ID generated by the STEP system
_	Separator
aa	Language abbreviation in accordance with ISO 639-1
AA	Country abbreviation in accordance with ISO-3166-1
--	Multilingual or international
vv	Document version, single or double digit: a, b, ...z; aa, ab, ...az; ba, bb, ...bz; etc.

- ¹ Some documents have different ID codes that are generated by an earlier system. There are also documents with up-to-date ID codes along with additional features in the designation.

ID code	Examples
ID_languageCOUNTRY_version -- = multilingual or international	A6V10215123_deDE_a A6V10215123_en--_a A6V10315123_----_a

Date format

The date format in the document corresponds to the recommendation of international standard ISO 8601 (format YYYY-MM-DD).

Conventions for text marking

Markups

Special markups are shown in this document as follows:

▷	Requirement for a behavior instruction
1. 2.	Behavior instruction with at least two operation sequences
–	Version, option, or detailed information for a behavior instruction
⇒	Intermediate result of a behavior instruction
⇒	End result of a behavior instruction
•	Numbered lists and behavior instructions with an operation sequence
[→ X]	Reference to a page number
'Text'	Quotation, reproduced identically
<Key>	Identification of keys
>	Relation sign and for identification between steps in a sequence, e.g., 'Menu bar' > 'Help' > 'Help topics'
↑ Text	Identification of a glossary entry

Supplementary information and tips



The 'i' symbol identifies supplementary information and tips for an easier way of working.

1.1 Applicable documents

Document ID	Title
A6V10208552	Installation Detector locking device FDBZ293
A6V10425603	OEM Radio fire detection system – Planning
A6V10425629	Installation Radio fire detector FDOOT271-O, Detector base FDB271
A6V10425605	FXS2061-O Wireless diagnostic tool User Guide
A6V10431682	Data sheet Radio fire detection system OEM
A6V10367669	Open-Source Software (OSS) Licenses



Applicable documents also include your installation manufacturer's technical manual and your radio gateway manufacturer's technical manual.

1.2 Download center

You can download various types of documents, such as data sheets, installation instructions, and license texts via the following Internet address:

<http://siemens.com/bt/download>

- Enter the document ID in the 'Find by keyword' input box.



You will also find information about search variants and links to mobile applications (apps) for various systems on the home page.

1.3 Technical terms and abbreviations

Term	Explanation
AI	Alarm indicator
Battery empty	Fault message in the event of a battery failing completely
Battery low	Fault message in the event that the spare battery is activated
IAI	Internal alarm indicator
LED	Light-emitting diode

1.4 History of changes

The reference document's version applies to all languages into which the reference document is translated.



The first edition of a language version or a country variant may, for example, be version 'd' instead of 'a' if the reference document is already this version.

The table below shows this document's revision history:

Modification index	Edition date	Brief description
e	2017-01-24	<ul style="list-style-type: none"> • Frequencies specified in 'Technical data' chapter • Chapter 'Detector dust cap FDZ291' added
d	2016-09-30	<ul style="list-style-type: none"> • Editorial changes
c	2015-10-15	<ul style="list-style-type: none"> • Editorial changes • Amendments in the following chapters: <ul style="list-style-type: none"> – Internal alarm indicator – Replacing the battery pack – Technical data
b	2015-04-01	<ul style="list-style-type: none"> • Editorial changes • Standardized presentation of the flashing behavior of the IAI
a	2014-05-01	First edition



The language versions and country variants produced by a local company have the same modification index as the corresponding reference document. They are not however included in the table below.

The table below shows the published language versions and country variants with the corresponding modification index:

Modification index	en_--	de_--	fr_--	it_--	es_--
e	X	X	–	–	–
d	X	X	–	–	–
c	–	X	–	–	–
b	–	X	–	–	–
a	–	X	–	–	–

X = published

– = no publication with this modification index

2 Safety

2.1 Safety instructions

The safety notices must be observed in order to protect people and property.

The safety notices in this document contain the following elements:

- Symbol for danger
- Signal word
- Nature and origin of the danger
- Consequences if the danger occurs
- Measures or prohibitions for danger avoidance

Symbol for danger



This is the symbol for danger. It warns of **risks of injury**.
Follow all measures identified by this symbol to avoid injury or death.

Additional danger symbols

These symbols indicate general dangers, the type of danger or possible consequences, measures and prohibitions, examples of which are shown in the following table:



General danger



Explosive atmosphere



Voltage/electric shock



Laser light



Battery



Heat

Signal word

The signal word classifies the danger as defined in the following table:

Signal word	Danger level
DANGER	DANGER identifies a dangerous situation, which will result directly in death or serious injury if you do not avoid this situation.
WARNING	WARNING identifies a dangerous situation, which may result in death or serious injury if you do not avoid this situation.
CAUTION	CAUTION identifies a dangerous situation, which could result in slight to moderately serious injury if you do not avoid this situation.
<i>NOTICE</i>	<i>NOTICE</i> identifies possible damage to property that may result from non-observance.

How risk of injury is presented

Information about the risk of injury is shown as follows:

	<p>⚠ WARNING</p>
	<p>Nature and origin of the danger Consequences if the danger occurs</p> <ul style="list-style-type: none"> • Measures / prohibitions for danger avoidance

How possible damage to property is presented

Information about possible damage to property is shown as follows:



	<p><i>NOTICE</i></p>
	<p>Nature and origin of the danger Consequences if the danger occurs</p> <ul style="list-style-type: none"> • Measures / prohibitions for danger avoidance

2.2 Safety regulations for the method of operation

National standards, regulations and legislation

Siemens products are developed and produced in compliance with the relevant European and international safety standards. Should additional national or local safety standards or legislation concerning the planning, mounting, installation, operation or disposal of the product apply at the place of operation, then these must also be taken into account together with the safety regulations in the product documentation.

Electrical installations

	<p>⚠ WARNING</p>
	<p>Electrical voltage Electric shock</p> <ul style="list-style-type: none"> • Work on electrical installations may only be carried out by qualified electricians or by instructed persons working under the guidance and supervision of a qualified electrician, in accordance with the electrotechnical regulations.
<ul style="list-style-type: none"> • Wherever possible disconnect products from the power supply when carrying out commissioning, maintenance or repair work on them. • Lock volt-free areas to prevent them being switched back on again by mistake. • Label the connection terminals with external voltage using a 'DANGER External voltage' sign. • Route mains connections to products separately and fuse them with their own, clearly marked fuse. • Fit an easily accessible disconnecting device in accordance with IEC 60950-1 outside the installation. • Produce earthing as stated in local safety regulations. 	
	<p>⚠ CAUTION</p>
	<p>Noncompliance with the following safety regulations Risk of injury to persons and damage to property</p> <ul style="list-style-type: none"> • Compliance with the following regulations is required.
	<ul style="list-style-type: none"> • Specialist electrical engineering knowledge is required for installation. • Only an expert is permitted to carry out installation work. <p>Incorrect installation can take safety devices out of operation unbeknown to a layperson.</p>

Mounting, installation, commissioning and maintenance

- If you require tools such as a ladder, these must be safe and must be intended for the work in hand.
- When starting the fire control panel ensure that unstable conditions cannot arise.
- Ensure that all points listed in the 'Testing the product operability' section below are observed.
- You may only set controls to normal function when the product operability has been completely tested and the system has been handed over to the customer.

Testing the product operability

- Prevent the remote transmission from triggering erroneously.
- If testing building installations or activating devices from third-party companies, you must collaborate with the people appointed.
- The activation of fire control installations for test purposes must not cause injury to anyone or damage to the building installations. The following instructions must be observed:
 - Use the correct potential for activation; this is generally the potential of the building installation.
 - Only check controls up to the interface (relay with blocking option).
 - Make sure that only the controls to be tested are activated.
- Inform people before testing the alarm devices and allow for possible panic responses.
- Inform people about any noise or mist which may be produced.
- Before testing the remote transmission, inform the corresponding alarm and fault signal receiving stations.

Modifications to the system design and the products

Modifications to the system and to individual products may lead to faults, malfunctioning and safety risks. Written confirmation must be obtained from Siemens and the corresponding safety bodies for modifications or additions.

Modules and spare parts

- Components and spare parts must comply with the technical specifications defined by Siemens. Only use products specified or recommended by Siemens.
- Only use fuses with the specified fuse characteristics.
- Wrong battery types and improper battery changing lead to a risk of explosion. Only use the same battery type or an equivalent battery type recommended by Siemens.
- Batteries must be disposed of in an environmentally friendly manner. Observe national guidelines and regulations.

Disregard of the safety regulations

Before they are delivered, Siemens products are tested to ensure they function correctly when used properly. Siemens disclaims all liability for damage or injuries caused by the incorrect application of the instructions or the disregard of danger warnings contained in the documentation. This applies in particular to the following damage:

- Personal injuries or damage to property caused by improper use and incorrect application
- Personal injuries or damage to property caused by disregarding safety instructions in the documentation or on the product
- Personal injury or damage to property caused by poor maintenance or lack of maintenance

2.3 Standards and directives complied with

A list of the standards and directives complied with is available from your Siemens contact.

2.4 Release Notes

Limitations to the configuration or use of devices in a fire detection installation with a particular firmware version are possible.

	⚠ WARNING
	<p>Limited or non-existent fire detection</p> <p>Personal injury and damage to property in the event of a fire.</p> <ul style="list-style-type: none"> • Read the 'Release Notes' before you plan and/or configure a fire detection installation. • Read the 'Release Notes' before you carry out a firmware update to a fire detection installation.

	NOTICE
	<p>Incorrect planning and/or configuration</p> <p>Important standards and specifications are not satisfied. Fire detection installation is not accepted for commissioning. Additional expense resulting from necessary new planning and/or configuration.</p> <ul style="list-style-type: none"> • Read the 'Release Notes' before you plan and/or configure a fire detection installation. • Read the 'Release Notes' before you carry out a firmware update to a fire detection installation.

3 Structure and function

3.1 Overview

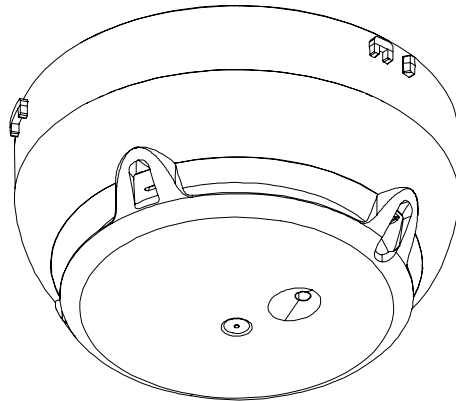

Properties

- Radio communication with:
 - Radio gateway
 - Other radio devices
- Software can be used to set as:
 - Neural fire detector
 - Heat detector
 - Wide-spectrum smoke detector
- Internal alarm indicator with status display (red and green):
 - Identifies alarm
 - Confirms positioning on detector base
 - Confirms contact with radio network
- Easy installation on the detector base

3.1.1 Details for ordering

Type	Order number	Designation
FDOOT271-O	S54323-F312-A1	Radio fire detector



The battery pack and detector base are not included in the scope of delivery. A battery pack and detector base are required for commissioning and operation.

3.1.2 Product version ES

The product version ES provides the technical status of a device in terms of software and hardware. The product version is provided as a two-digit number.

You will find the details of your device's product version:

- On the packaging label
- On the product label or the type plate

Product version on the packaging label

Details of the product version can be found directly on the packaging label in the barcode:

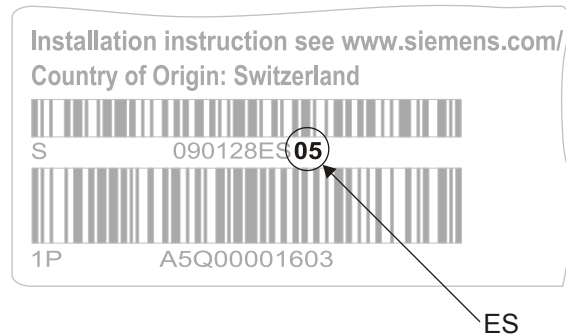

Figure 1: Example of a packaging label with details of the product version

Product version on the product label and the type plate

Details of the product version can be found after the device order number:

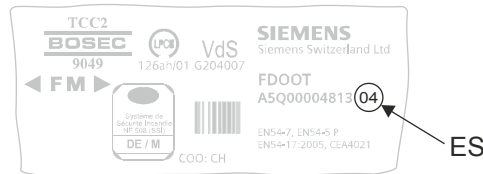

Figure 2: Example of a product label with details of the product version



Depending on the product and various approvals, the product labels may differ in terms of the information type and layout.

Look for your device's order number on the product label.

You will find the product version after the order number.

3.1.3 Sensory

The radio fire detector has optical and thermal sensors. The radio fire detector can be parameterized as a smoke detector or a heat detector.

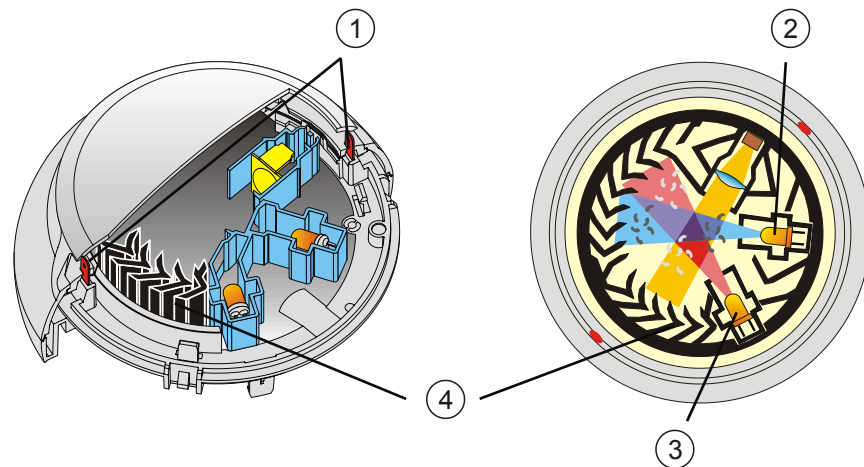

Figure 3: Fire detector structure

- | | |
|----------------------|---------------------|
| 1 Heat sensors | 3 Forward scatterer |
| 2 Backward scatterer | 4 Labyrinth |

The radio fire detector has a sophisticated opto-electronic measuring chamber with two optical transmitters, an optical receiver, and two thermal sensors.

The transmitters illuminate the smoke particles from different angles. One sensor acts as forward scatterer, the other as backward scatterer. The scattered light then hits the receiver (photo diode) and generates a measurable electric signal.

The combination of a forward and backward scatterer facilitates an optimum detection and the differentiation of light and dark particles, which leads to a homogenous response behavior and optimizes the differentiation of wanted signals and deceptive phenomena.

The combination of optical and thermal sensor signals optimizes detection reliability. This has the following advantages:

- Early detection of all types of fire, whether they generate light or dark smoke, or no smoke at all.
- The neural fire detector can be operated at a lower sensitivity level and thus achieves a higher immunity against false alarms which can be caused by cold aerosols (e.g., by smoking, electrical welding, etc.). In the case of an open fire, the smoke sensitivity is heightened by the temperature increase, which means that a detection reliability level that is comparable to that of the wide-spectrum smoke detector can be achieved.

In addition, the heat sensors make it possible to detect fires without smoke generation.

The radio fire detector can be used purely as an optical smoke detector or purely as a heat detector. This is determined by selecting one of the following sensor modes (using the control panel):

- Sensor mode 0: Application as neural fire detector
- Sensor mode 1: Application as heat detector
- Sensor mode 2: Application as smoke detector

3.2 Power supply

The battery pack BAT3.6-10 supplies the radio devices with power. The battery pack consists of lithium batteries plus a battery cable and a battery connector.

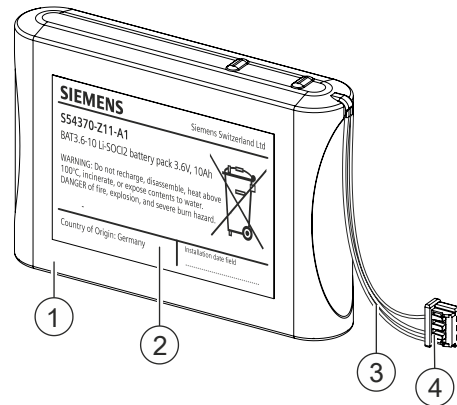

Figure 4: Battery pack BAT3.6-10

- 1 Battery pack consisting of:
 - 4 lithium batteries for normal operation
 - 1 lithium battery as a spare in the case of 'Battery low' operation
 - 2 Label with area for filling in the commissioning date
 - 3 Battery cable
 - 4 Battery connector with protection against polarity reversal
- In normal operation: Can be used for the service life stated
 - In 'Battery low' operation: subject to reduced operating life
 - Connections cannot be reversed thanks to battery connector with protection against polarity reversal

3.3 Function

3.3.1 Parameter sets

The detection behavior of the detectors is influenced by the parameter sets, so that it can be specifically adjusted to the fire phenomena and environmental conditions to be expected in the environment to be monitored.

The parameter sets for smoke and heat detection are programmed in the detectors. During commissioning, the optimum parameter set must be selected for the conditions at the place of installation. This is carried out using the control panel.

3.3.2 Danger levels

The detector's signal processing efficiently distinguishes between fire events and deceptive phenomena. The basis for reaching a danger level is not only given by measured values exceeding a 'response threshold'; moreover, the smoke density progression is observed over a longer period of time and assessed by the algorithms.

Fire detectors can transmit the following danger levels to the control panel:

Danger level	Meaning	Comment
0	No danger	Normal condition
1	Check the situation.	A different parameter set should potentially be selected (inappropriate application)
2	Warning	Possible danger
3	Alarm	Fire

The evaluation of the danger level and the decisions to be taken (e.g., activation of remote transmission) are configured in the control panel.

3.3.3 Diagnosis levels

The detector monitors its operation largely autonomously. The signals of all sensors are permanently monitored. In particular, the temperature sensors, light emitters, and light receivers are monitored to ensure that they are functioning correctly. Signal processing takes account of the monitoring results and adapts its behavior accordingly.

The following diagnosis levels are derived from the different control measurements:

- Normal
- Observe information
- Replacement recommended
- Replacement necessary
- Fault

When an error occurs which impairs the correct functionality of the detector, a fault message is reported to the control panel. To correct the cause of the fault, additional information is available in the detector. The diagnosis levels can be read out using the FXS2061-O Wireless diagnostic tool. You will find more information in document A6V10425605.

3.3.4 Internal alarm indicator

The internal alarm indicator's LED has two colors and shows the operating condition of the radio fire detector.

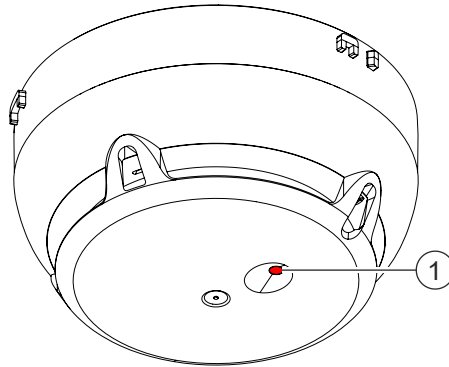

1 Internal alarm indicator

The table below describes the flashing behavior of the internal alarm indicator in the radio fire detector FDOOT271-O:



Several flashing patterns are available for normal operation. The flashing pattern is selected using the panel configuration program.

Operating condition		Flashing mode	Graphic
Alarm		IAI flashes red once a second	
Alarm in test mode		IAI flashes green twice every four seconds and red every second in-between	
Fault	There is an error.	IAI flashes red four times every second	
Commissioning	The radio fire detector has not yet been logged on to a radio gateway And The radio fire detector is not mounted on a detector base. And There is no contact with the radio network.	IAI flashes red once every two seconds	

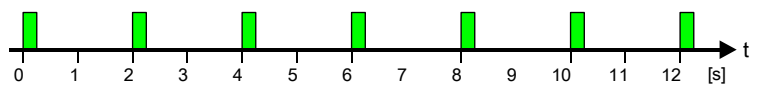
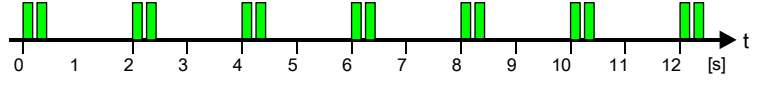
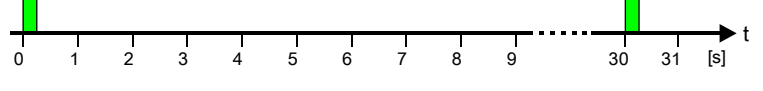
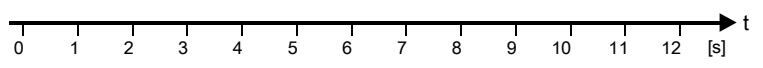
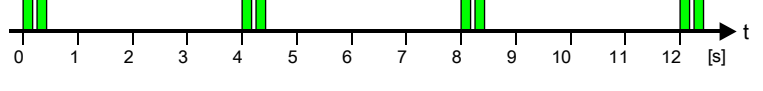
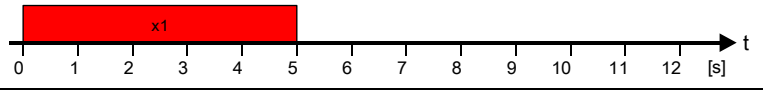
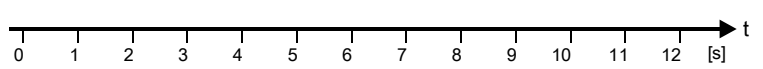
Operating condition		Flashing mode	Graphic
	The radio fire detector has already been logged on to a radio gateway And The radio fire detector is not mounted on a detector base. And There is no contact with the radio network.	IAI flashes green once every two seconds	
	The radio fire detector is mounted on the base but has not yet been logged on to the radio network.	IAI flashes green twice every two seconds	
Normal	Configuration 1	IAI flashes green once every 30 seconds	
	Configuration 2	IAI off	
Test		IAI flashes green twice every four seconds	
New battery		IAI lights up once for five seconds	
Battery is flat		IAI off	



Several operating conditions may be indicated at the same time. This may lead to the flashing patterns overlapping one another. The red LED indicator has priority over the green LED indicator.

Flashing patterns with a higher frequency will overlap those with a lower frequency, which means that the latter may no longer be discernible.



Not all fire control panels support the flashing patterns described.

Please also observe the documentation for your fire detection system.

3.3.5 Renovation mode

Renovation mode is set using the control panel.

Renovation mode can be used under the following conditions:

- If there is a large amount of dust in the air around the radio fire detector temporarily
- If there are aerosols in the air around the radio fire detector temporarily

The radio fire detector does not issue alarms in renovation mode until a temperature of 80 °C has been exceeded for 20 seconds.

You will find more detailed information in the fire detection system documentation.

3.3.6 Test mode

In test mode the radio fire detectors react faster and with a higher sensitivity level.

For testing purposes, the radio fire detectors can be set to test mode using the control panel or the FXS2061-O Wireless diagnostic tool.

The following tests can be performed:

- Test of optical detector function using test gas
- Test of heat detector function using hot air

You will find more detailed information in the fire detection system documentation.

3.3.7 Interface to service devices

The fire control panel or the software FXS2061-O Wireless diagnostic tool is used to read out and set the parameter sets.

3.4 Mechanical setup

A mounted detector base FDB271 is required to mount the detector.

Once the detector is ready for use, twist it onto the detector base either manually or using the detector exchanger.

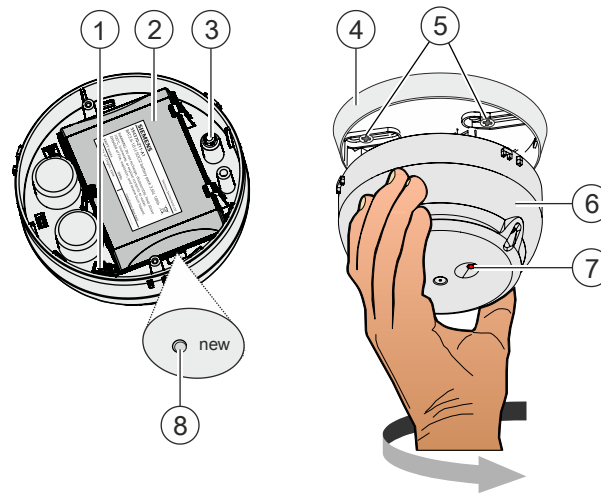

Figure 5: Mechanical setup

- | | |
|---------------------|----------------------------|
| 1 Battery connector | 5 Fixing screws |
| 2 Battery pack | 6 Detector |
| 3 Switch | 7 Internal alarm indicator |
| 4 Detector base | 8 'new' button |

See also

📄 Accessories [→ 23]

3.5 Accessories

3.5.1 Battery pack BAT3.6-10

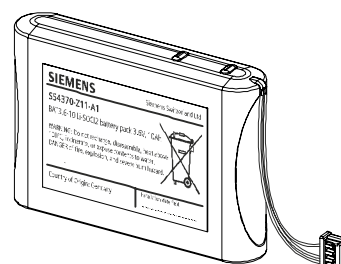

- For supplying radio devices and the radio gateway with power
- Lithium batteries
 - BAT3.6-10 LI-SOCI2 battery pack 3.6 V, 10 Ah
- Batteries with battery cable
- Connector system with protection against polarity reversal
- Inscription field for commissioning date
- Compatible with:
 - Radio manual call point FDM273-O
 - Radio manual call point FDM275-O
 - Radio fire detector FDOOT271-O
- Order number: S54370-Z11-A1

3.5.2 Detector base FDB271

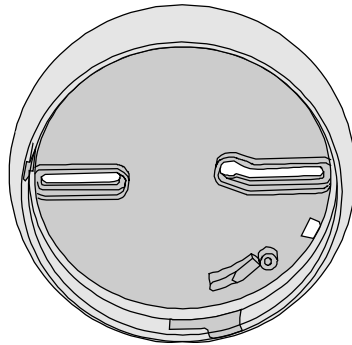

- For installing radio fire detectors
- Directly attached to the mounting surface
- Fastened with two screws
- Compatible with:
 - Radio fire detector FDOOT271-O
- Order number: S54319-F12-A1

3.5.3 Detector locking device FDBZ293



- For protection against theft
- Compatible with:
 - Radio fire detector FDOOT271-O
- Order number: A5Q00005035

3.5.4 Designation plate FDBZ291

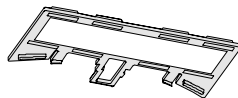

- To identify the location
- Compatible with:
 - Detector base FDB271
- Order number: A5Q00002621

3.5.5 Detector dust cap FDZ291

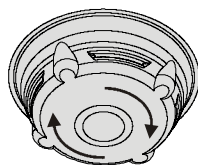

- Protects the detector against dust
- Compatible with:
 - Point detectors
 - Alarm sounders
- Order number: A5Q00004814

4 Planning

4.1 Ambient features

In selecting the optimum parameter set, the following factors must be taken into account:

- Risk of damage to persons
- Value concentration
- Room geometry
- Deceptive phenomena
- Risk of fire
- Critical fire size

Risk of damage to persons

People's lives are severely at risk in venues such as concert halls, nursing homes, and hospitals. The risk of damage to persons is therefore very high in such places. In canteen kitchens the situation is different. Few people work in such facilities and are able to save themselves in the event of timely alarms. The risk of damage to persons is thus rather low in this case.

Value concentration

Irreplaceable cultural assets are often on display in museums. Computer centers house servers with large data volumes. The concentration of valuable items is rather high. In a normal hotel room the concentration of valuable items must be classified as low.

Room geometry

High ceilings, complex room shapes or well-ventilated rooms have a complex room geometry. This aggravates early fire detection, as it is difficult for the fire phenomenon to reach the fire detector. An office room with normal ceiling height has a simple room geometry.

Deceptive phenomena

Deceptive phenomena can deceive a fire detector and bring about a false alarm. The deceptive phenomena differ depending on the fire detector. Examples of deceptive phenomena include steam, cigarette smoke, dust, dry ice in discotheques, exhaust fumes, aerosols occurring during welding, and heat sources such as radiant heaters or hot engines.

In a small hotel room with a rather low ceiling where vapor from the bathroom may penetrate the room, or in operating facilities where a lot of dust is generated, many deceptive phenomena must be taken into consideration. In a clean room where electronic modules are fabricated the risk of deceptive phenomena is rather low.

Risk of fire

In production facilities where highly combustible materials such as flammable liquids, cotton, paper, etc., are processed and where electrical machines are operated, the risk of fire is very high. Minor overheating or sparks may cause a fire. In a storehouse where steel is stored and where no electrical installation is provided with the exception of lighting, the fire risk is very low.

Critical fire size

When a waste paper basket in a metal-processing facility catches fire, the consequential damage is usually rather low. Here we are talking about a critical, medium fire size that can still be tolerated. The situation is completely different in pharmaceutical production facilities where even the lowest smoke concentration may impair the process and where combustible materials are processed. Even the smallest fire must be detected immediately. Therefore, we need to define what is termed a small admissible critical fire size.

4.2 Parameter sets for FDOOT271-O

4.2.1 Sensor mode 0 'Neural fire detector'

4.2.1.1 Description

(Parameter set numbers in brackets)

Robust (0)/(2):

The priority of the 'Robust' parameter set is to a robust response. It is thus particularly suited to application in rooms where deceptive phenomena such as cigarette smoke or dust can be expected. The 'Robust (2)' parameter set is suitable for higher rooms.

Suppression (5):

Thanks to its very robust behavior, the 'Suppression' parameter set is particularly suitable for rooms where deceptive phenomena such as cigarette smoke or exhaust fumes can be expected. It reacts in a very robust way to the deceptive phenomenon vapor.

Fast Response (6):

This parameter set reacts in a fast and highly sensitive manner. It is thus especially suited for rooms without deceptive phenomena, where the priority is on detecting the fire as early as possible.

4.2.1.2 Use

No.	Name	Risk of damage to persons	Concentration of valuable items	Room geometry	Deceptive phenomena	Risk of fire	Critical fire size
		small... large	low... high	simple... complex	few... many	small... large	small... medium
0	Robust						
2	Robust						
5	Suppression						
6	Fast Response						

4.2.1.3 Specification

The following table displays the properties and fields of application of the parameter sets of radio fire detector FDOOT271-O in sensor mode 0.

No.	Name	Optical			Thermal		
		Typ. Response time from - typ. - to	Sensitivity, open fire	Sensitivity, smoldering fire	Static activation temperature	Differential activation temperature ¹	Differential activation possible from:
		[s]	[%/m]	[%/m]	[°C]	ΔT [K]	[°C]
0	Robust	80	3.2	11.4	80	29	30
2	Robust	80	3.2	11.4	80	29	30
5	Suppression	90 - 160 - 760	3.2	11.4	80	29	30
6	Fast Response	20 - 30	1.6	5.6	80	22	3

¹ Applicable with fast temperature increases >10 K/min.



All parameter sets comply with standards EN 54-7 and CEA 4021.

4.2.2 Sensor mode 1 'Heat detector'

4.2.2.1 Description

This sensor mode is especially suited for applications where the detector should only react thermally.

The heat detector FDOOT271-O has the following parameter sets:

- A1R (1)
- A1S (3)

Notes on A1 designations

- A1 parameter sets should be operated at a room temperature of around 25 °C. However, they can be applied at temperatures up to 50 °C. The static response temperature is 60 °C.

Notes on the designations R and S

Compared with S parameter sets, R parameter sets also trigger an alarm when the temperature increases (e.g., from 20 °C to 50 °C within a few minutes).

4.2.2.2 Specification

No.	Name	Operating temperature typ. / max.	Static activation temperature ¹	Differential activation temperature ²	Differential activation possible from:
		[°C]	[°C]	ΔT [K]	[°C]
1	A1R 60 °C rate of rise	25 / 50	60	25	3
3	A1S 60 °C maximum	25 / 50	60	–	–

¹ Applicable with slow temperature increases <1 K/min.

² Applicable with fast temperature increases of >10 K/min. When there is a slow temperature increase of <10 K/min, this value rises by a few degrees.



Both parameter sets meet the criteria of standard EN 54-5.

4.2.3 Sensor mode 2 'Smoke detector'

4.2.3.1 Description

This sensor mode should be selected if fast temperature changes that are not caused by fire may occur (e.g., in the case of radiant heaters, hot engines). In this sensor mode the detector only reacts optically; this is comparable with a wide-spectrum smoke detector. However, because it has a second optical sensor, it reveals a more balanced response behavior in relation to the different types of fire.

Universal (1):

With 'Universal' the sensitivity and response time to aerosols are between 'Robust' and 'Sensitive'.

Robust (2):

This parameter set responds to aerosols in a similar way as the neural fire detector FDOOT271-O in sensor mode 0 with the 'Robust' parameter set, without taking into account the temperature.

Sensitive (3):

With regard to aerosols, this parameter set reacts in a way that is comparable to 'Fast Response' in sensor mode 0 without temperature influence.

4.2.3.2 Use

No.	Name	Risk of damage to persons	Concentration of valuable items	Room geometry	Deceptive phenomena	Risk of fire	Critical fire size
		small... large	low... high	simple... complex	few... many	small... large	small... medium
1	Universal						
2	Robust						
3	Sensitive						

4.2.3.3 Specification

No.	Name	Response time [s]	Sensitivity open fire/smoldering fire [%/m]
1	Universal	50	2.3 / 8
2	Robust	80	2.3 / 8
3	Sensitive	30	1.6 / 5.6



All parameter sets meet the criteria of standard EN 54-7.

4.3 Application examples

Please contact your system manufacturer for application recommendations, such as choosing the detector type and its settings for various applications.

5 Mounting / Installation

5.1 Required space

- Upon insertion of the detector, the detector base is stressed by compression, tension and torsion. The fixing must thus be designed accordingly.
- Detector bases must be placed flat on the ceiling.
- Avoid mounting on steps, concrete ribs, etc.
- When selecting the installation position, take into account any structures that may impair radio reception.

5.2 Detector base FDB271

The detector base must be securely connected to the substructure.

Screw the detector base securely onto the substructure using two screws.

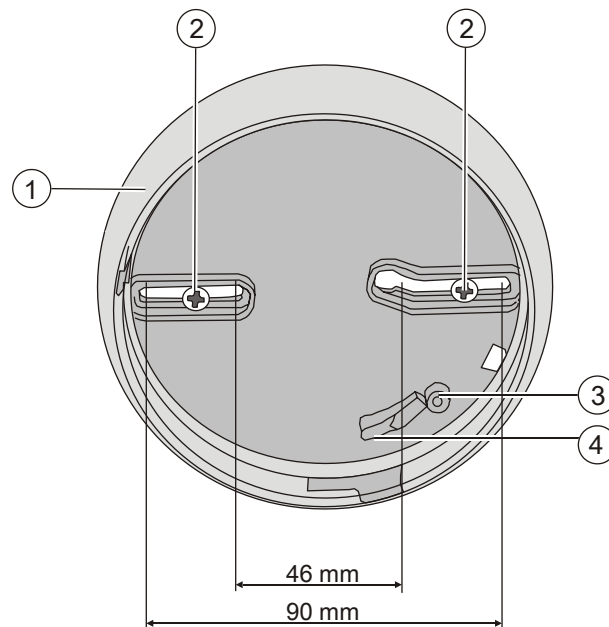

Figure 6: Mounting the detector base

- 1 Detector base
- 2 Screws with max. \varnothing of 4 mm
- 3 Holder for detector locking device
- 4 Switching cam

5.3 Mounting radio fire detector FDOOT271-O



The action of inserting the radio fire detector into the detector base activates it; the detector then logs on to other radio devices immediately. Therefore, start from the radio gateway and work outwards to install the individual radio fire detectors.

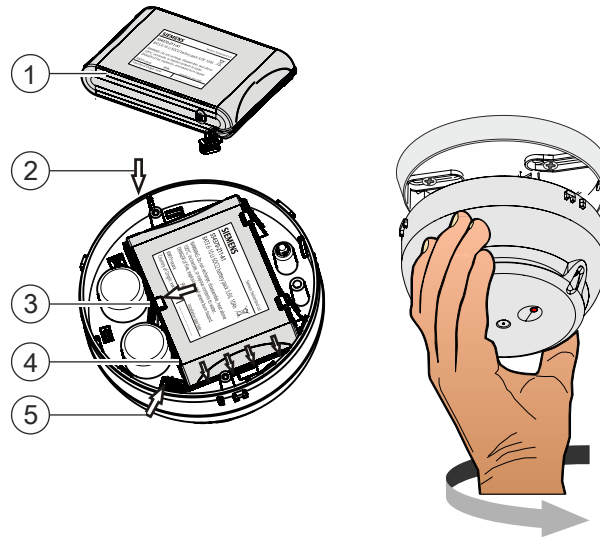

Figure 7: Mounting the radio fire detector

- | | |
|---------------------------------------|---------------------|
| 1 Battery pack BAT3.6-10 ¹ | 4 Battery cable |
| 2 Inserting the battery pack | 5 Battery connector |
| 3 Holder | |

¹ Not included in the scope of delivery





The flashing behavior of the internal alarm indicator is described in the 'Internal alarm indicator [→ 20]' chapter.

- ▷ The radio gateway has been activated and switched to maintenance mode.
- ▷ The radio fire detector is set to the factory settings. [→ 38]
- ▷ You have the battery pack and the required accessories to hand.
- ▷ The detector base FDB271 is mounted. [→ 30]

1. Install the accessories you require.
 2. Label the new battery pack (1) with the current date.
 3. Connect the battery connector (5) of the new battery pack.
 4. Insert the new battery pack (1), paying attention to the position of the battery cable (arrows at 4).
 5. Make sure that the holder (3) latches into place correctly.
 - ⇒ When the battery connector is connected, the internal alarm indicator lights up red for 5 seconds.
 - ⇒ After a further 10 seconds, the radio fire detector signals that it is not installed on the detector base and the internal alarm indicator flashes. If it flashes red, this indicates the factory settings. If it flashes green, this indicates that the radio fire detector has already been logged on to a radio gateway.
 - ⇒ If this does not happen, this means the battery pack is defective and must not be used.
 6. Insert the radio fire detector into the detector base.
 - ⇒ The internal alarm indicator flashes green and the radio fire detector is logged on to the radio gateway.
 - ⇒ If the process of logging on to the radio gateway is successful, the internal alarm indicator stops flashing.
- ⇒ The radio fire detector is now installed and is ready for commissioning.

See also

-  Internal alarm indicator [→ 20]
-  Internal alarm indicator [→ 20]

5.4 Detector locking device FDBZ293

The detector can be protected against theft with the detector locking device FDBZ293.

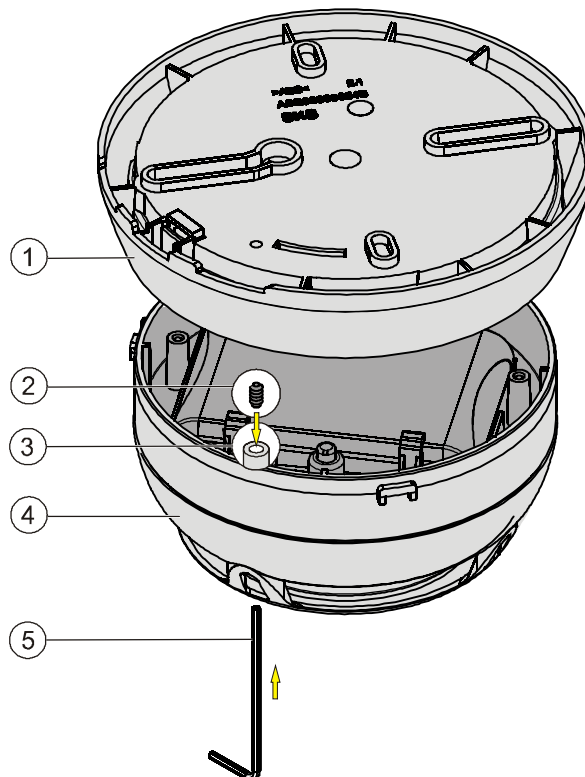

Figure 8: Mounting of detector locking device FDBZ293

- | | |
|-----------------------------------|-------------|
| 1 Detector base | 4 Detector |
| 2 Set screw with a hexagon socket | 5 Allen key |
| 3 Hole | |

1. Place the 'set screw with a hexagon socket' (2) in the hole (3) on the detector (4).
 2. Insert the detector (4) into the detector base (1).
 3. Using the Allen key provided (5), insert the 'set screw with a hexagon socket' (2) through the hole in the detector base (1) and tighten.
- ⇒ The detector can no longer be removed from the base without tools.

6 Commissioning

When the battery connector is connected, the radio fire detector FDOOT271-O is activated. Once inserted into the detector base, the radio fire detector automatically looks for radio devices within range in the vicinity and automatically integrates itself into the radio network.



Insert the battery packs into the devices at the location where they are going to be used just before commissioning the fire detection installation.

The device is commissioned via the control panel. The exact procedure is described in the control panel documentation.

Conduct a performance check once commissioning is complete.

You will find additional information in the following documents:

- Document A6V10425603

See also

 [Applicable documents \[→ 7\]](#)

7 Maintenance / Repair

Check the detector on a regular basis, but at least once a year.

To do this, look for/check the following and resolve any problems you identify:

- Mechanical damage
- Soiling
- Correct fastening
- Detector function by means of test activation

7.1 Status query

The query is issued from the control panel, via the radio gateway.

The following queries may be issued:

- Danger level
- Detector fault
- Radio status

Depending on the authorization level of the user and the control panel type, the following actions can be performed:

- Device test (Go/No Go or detailed by status polling)
- Activation of a test alarm
- Reading out the identification number, customer text and measure text
- Localizing and setting the parameters of the detector
- Switching off the detector

See also

- 📖 [Diagnosis levels \[→ 19\]](#)
- 📖 [Internal alarm indicator \[→ 20\]](#)

7.2 Performance check

The selftest automatically subjects the detectors to an extensive electrical performance check. Regular performance checks of the detectors are required nonetheless. These can be performed using test gas or hot air.

Recommendation:

- Perform a visual inspection on all detectors every year. Detectors that are heavily soiled or mechanically damaged must be replaced.
- All detectors should be replaced after 6 to 8 years of service, depending on the ambient conditions.

7.3 Testing detectors

Depending on the sensor mode, testing may be performed with one or more of the following tools:

- Test gas
- Hot air

The following table shows which mode may be tested with which test aid.

Mode	Test gas	Hot air	Wireless diagnostic tool
Sensor mode 1	–	X	Communication
Sensor mode 2	X	–	Communication

The fire detectors are highly resistant to deceptive phenomena. This means that optical fire detectors, for example, will recognize the immediate occurrence of smoke (such as that which occurs during testing with test gas) as a deceptive phenomenon and will not trigger an alarm. This is desirable in normal operation; however, it does make testing with test gas problematical.

To enable detector testing with test gas or hot air, the detector must be switched to test mode. Testing with test gas or hot air is performed differently on addressed detector lines and collective detector lines.

Proceed as follows:

1. First switch the zone to 'Test' on the control panel.
2. Then perform the test using test gas.



To trigger a detector using test gas, normally 2...4 gas discharges at intervals of approx. 2 seconds are required. When the detector is working in test mode, activation takes place after approximately 10 seconds.

7.4 Confirming the detector position

Use the manufacturer documentation for the radio gateway to confirm the detector position.

7.5 Establishing factory settings

All existing settings are deleted and reset to the factory settings.

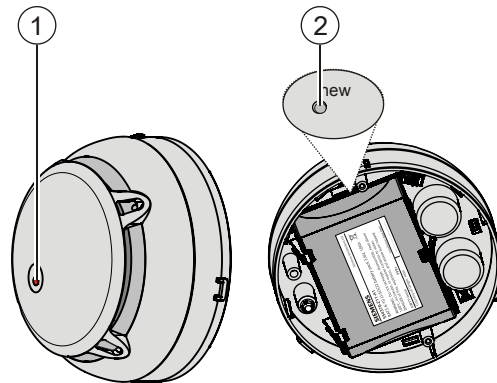

Figure 10: Establishing factory settings

- 1 Internal alarm indicator
- 2 'new' opening with button

To create the factory settings on the radio fire detector, proceed as follows:

- ▷ The radio fire detector is being supplied with power.
 - ▷ You have a slim pen or pencil to hand.
1. Remove the radio fire detector from the detector base.
 2. Wait until the internal alarm indicator (1) flashes green (2-second interval).
 - ⇒ The detector is 'out of base'.
 3. Press the pen or pencil into the 'new' opening (2) for 5 seconds.
 - ⇒ The internal alarm indicator flashes red (2-second interval).
- ⇒ The radio fire detector is set to the factory settings.

See also

- 📄 Internal alarm indicator [→ 20]

7.6 Basic principles for replacing the battery pack

	⚠ WARNING
	<p>Risk of explosion due to fire or short-circuit, even if the battery pack is discharged Injuries caused by flying parts</p> <ul style="list-style-type: none"> • To prevent the connection wires short-circuiting, insulate the connections and stick the battery cable to the battery pack. • Do not allow the battery pack to come into contact with water. • Do not extinguish a burning battery pack with water. • Do not recharge the battery pack. • Do not damage or dismantle the battery pack. • Do not heat the battery pack to more than 100 °C.

	⚠ WARNING
	<p>Disposing of damaged or leaky battery packs Lithium can burn the skin and produce toxic vapors.</p> <ul style="list-style-type: none"> • Avoid direct contact with the body. Wear appropriate protective clothing (safety gloves, safety goggles, etc.). Use appropriate means of transportation to move damaged batteries around. • Do not breathe in vapors. Ensure that there is sufficient ventilation.

Always observe the following information:

- When the control panel issues the message 'Battery low', replace the battery pack.
- Use the control panel to identify the location of the radio device.
- Only use battery pack BAT3.6-10.
- The battery pack must be new and free from damage. The battery cable is attached to the battery pack with an adhesive label.
- Store, transport, and dispose of the battery pack in accordance with local regulations, guidelines, and laws.
- Label the battery pack with the commissioning date.

See also

- 📖 Environmental compatibility and disposal [→ 45]

1. Remove the detector from the detector base.
 2. Wait until the internal alarm indicator flashes green (interval: 2 seconds).
 - ⇒ The detector is 'out of base'.
 3. Push the holder (4) to the side and remove the battery pack (1).
 4. Release the battery connector (6).
 5. Dispose of the old battery pack.
 6. Label the new battery pack with the current date.
 7. Connect the battery connector (6) of the new battery pack.
 8. Insert the new battery pack, paying attention to the position of the battery cable (arrows at 5).
 9. Make sure that the holder (4) latches into place correctly.
 - ⇒ When the battery connector is connected, the internal alarm indicator lights up red for 5 seconds (flashing pattern number 1 Internal alarm indicator).
 - ⇒ After a further 10 seconds, the detector signals that it is not installed on the detector base and the internal alarm indicator flashes green (flashing pattern number 3).
 - ⇒ If this does not happen, this means the battery pack is defective and must not be used.
 10. Insert the detector into the detector base.
 - ⇒ The internal alarm indicator flashes green (flashing pattern number 4) and the detector is logged on to the radio gateway.
 - ⇒ If the process of logging on to the radio gateway is successful, the internal alarm indicator stops flashing.
 11. Following the successful logon, replace the battery pack of the next radio device.
 12. Check the status display on the radio gateway or the 'Device localization error' display on the control panel.
 - If there is a 'Device localization error' message on the radio gateway or the control panel, the detector will need to be assigned again. Assign the detector by following the information in Confirming the detector position.
- ⇒ The battery pack has now been replaced.

See also

- 📄 Internal alarm indicator [→ 20]

8 Specifications

8.1 Technical data

You will find information on approvals, CE marking, and the relevant EU directives for this device (these devices) in the following document(s); see 'Applicable documents' chapter:

- Document A6V10431682

Device characteristics	Response sensitivity	2.3...12 %/m
	Compensation speed	≤1/45 voltage increase for detection/h
	Detector diagnosis	With Wireless diagnostic tool or connected fire control panel
Radio	Sending/receiving aerials	Dual band aerial
	Frequency range	433.05...434.79 MHz in band 44b and 45b ¹ 868...870 MHz in band 48, 49, 50, 54b, and 56b ¹
	Channel grid	50 kHz
	Number of channels	27 in 868-MHz band 20 in 433-MHz band
	Transmitting power	≤10 mW ERP in band 44b, 45b, and 49 ¹ Type 10 (max. ≤25) mW ERP in band 48, 50, 54b, and 56b ¹
	Range	See document 'A6V10425603'
		¹ 2013/752/EU: according Official Journal of the European Union, COMMISSION IMPLEMENTING DECISION of 11 December 2013 amending Decision 2006/771/EC on harmonisation of the radio spectrum for use by short-range devices and repealing Decision 2005/928/EC (notified under document C(2013) 8776) (Text with EEA relevance)
Battery pack BAT3.6-10	Lithium battery pack	BAT3.6-10 LI-SOCI2 battery pack 3.6 V, 10 Ah
	Battery service life	At least 3 years depending on ambient conditions
	Service life in 'battery low' operation	>3 months
	Battery voltage monitored	Yes
	Weight	0.093 kg

Ambient conditions	Operating temperature:	-10...+55 °C
	Storage temperature	-30...+75 °C
	Air humidity	≤95 % rel.
	Protection category (IEC 60529):	IP44
	Electromagnetic compatibility:	
	100 kHz...2.5 GHz	30 V/m
	Permissible wind speed:	Max. 5 m/s
Mechanical data	Weight without accessories	0.132 kg
	Housing material	Acrylonitrile-butadiene-styrene (ABS)
	Color	~RAL 9010 pure white
Standards	European standards	<ul style="list-style-type: none"> • EN 54-11 • EN 54-25 • EN 300220-2 • EN 301489-3 • EN 60950-1

8.2 Dimensions

Radio fire detector FDOOT271-O with detector base FDB271

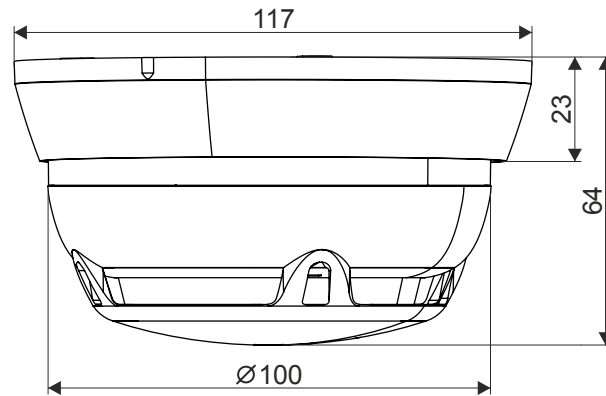

8.3 Environmental compatibility and disposal



This equipment is manufactured using materials and procedures which comply with current environmental protection standards as best as possible. More specifically, the following measures have been undertaken:

- Use of reusable materials
- Use of halogen-free plastics
- Electronic parts and synthetic materials can be separated

Larger plastic parts are labeled according to ISO 11469 and ISO 1043. The plastics can be separated and recycled on this basis.



Electronic parts and batteries must not be disposed of with domestic waste.

- Take electronic parts and batteries to local collection points or recycling centers.
- Contact local authorities for more information.
- Observe national requirements for disposing of electronic parts and batteries.

Glossary

Factory setting

Basic settings present at the time of delivery

Radio device

Any device that the radio gateway monitors

Radio network

Within a radio cell, bidirectional radio connections are established between the radio devices. Together with the radio gateway connections, these create a radio network.



Index

A	
Approvals	42
B	
Battery pack	
Description.....	23
Replacing	40
Replacing the battery pack.....	39
C	
CE marking.....	42
Control panel	35
D	
Danger level	
Signal processing of the detector	19
Detection behavior of the detector	
Parameter set.....	19
Diagnosis levels	19
Disposal	45
Documentation for fire detection system.....	21
Download center	
URL.....	8
E	
Environmental compatibility	45
ES	
Product version.....	16
EU directives	42
F	
Flashing mode	
Internal alarm indicator	20
Flashing pattern	
Configuration	20
Internal alarm indicator	20
I	
Intended use.....	5
O	
Original language	6
P	
Packaging label	
Product version.....	16
Parameter set	
Detection behavior of the detector.....	19
Product label	
Product version.....	16
R	
Recycling	45
S	
Signal processing of the detector	
Danger level	19
Source language	6
Standards.....	43
T	
Type plate	
Product version.....	16

Issued by
Siemens Switzerland Ltd
Building Technologies Division
International Headquarters
Gubelstrasse 22
CH-6301 Zug
+41 41-724 24 24
www.siemens.com/buildingtechnologies

© Siemens Switzerland Ltd, 2014
Technical specifications and availability subject to change without notice.